

# MITSUBISHI MODBUS® Interface Module

User's Manual  
(Hardware)

## QJ71MB91

Thank you for purchasing the Mitsubishi programmable controller MELSEC-Q Series.

Prior to use, please read both this and the detailed manual thoroughly and familiarize yourself with the product.

**MELSEC-Q**  
Mitsubishi Programmable  
Controller

MODEL	QJ71MB91-U-HW
MODEL CODE	13JP83
IB(NA)-0800329-D(0808)MEE	

## ● SAFETY PRECAUTIONS ●

(Always read these instructions before using this equipment.)

Before using this product, please read this manual and the relevant manuals introduced in this manual carefully and pay full attention to safety to handle the product correctly.

The instructions given in this manual are concerned with this product.

For the safety instructions of the programmable controller system, please read the user's manual of the CPU module used.

In this manual, the safety instructions are ranked as "DANGER" and "CAUTION".



**DANGER**

Indicates that incorrect handling may cause hazardous conditions, resulting in death or severe injury.



**CAUTION**

Indicates that incorrect handling may cause hazardous conditions, resulting in medium or slight personal injury or physical damage.

Note that the  **CAUTION** level may lead to a serious consequence according to the circumstances.

Always follow the instructions of both levels because they are important to personal safety.

Please save this manual to make it accessible when required and always forward it to the end user.

### [Design Precautions]



**DANGER**

- For the operating status of each station in the case of a communication error, see the manual of each station. Erroneous output or malfunction may cause an accident.

## [Design Precautions]

### **DANGER**

- When connecting a peripheral device to the CPU module or connecting a personal computer or the like to the intelligent function module / special function module to exercise control (data change) on the running programmable controller, configure up an interlock circuit in the sequence program to ensure that the whole system will always operate safely. Also before exercising other control (program change, operating status change (status control)) on the running programmable controller, read the manual carefully and fully confirm safety. Especially for the above control on the remote programmable controller from an external device, an immediate action may not be taken for programmable controller trouble due to a data communication fault. In addition to configuring up the interlock circuit in the sequence program, corrective and other actions to be taken as a system for the occurrence of a data communication fault should be predetermined between the external device and programmable controller CPU.
- Do not write any data in the "system area (Use prohibited)" of the buffer memory of the intelligent function module. Also, do not output (turn on) the "use prohibited" signal, which is one of the output signals from the programmable controller CPU to the intelligent function module. If data is written to the "system area (Use prohibited)" or the "use prohibited" signal is output, there is a risk that the programmable controller system may malfunction.

### **CAUTION**

- Do not bunch the control wires or communication cables with the main circuit or power wires, or install them close to each other. They should be installed 100 mm (3.94 inch) or more from each other. Not doing so could result in noise that would cause erroneous operation.

## [Installation Precautions]

### **CAUTION**

- Use the programmable controller in the operating environment that meets the general specifications described in the user's manual of the CPU Module to use. Using this programmable controller in an environment outside the range of the general specifications could result in electric shock, fire, erroneous operation, and damage to or deterioration of the product.

## [Installation Precautions]

### CAUTION

- While pressing the installation lever located at the bottom of module, insert the module fixing tab into the fixing hole in the base unit until it stops. Then, securely mount the module with the fixing hole as a supporting point. Incorrect loading of the module can cause a malfunction, failure or drop. When using the programmable controller in the environment of much vibration, tighten the module with a screw.
- Tighten the screw in the specified torque range.  
Undertightening can cause a drop, short circuit or malfunction.  
Overtightening can cause a drop, short circuit or malfunction due to damage to the screw or module.
- Completely turn off the externally supplied power used in the system before mounting or removing the module. Not doing so could result in damage to the product.
- Do not directly touch the module's conductive parts or electronic components. Touching the conductive parts could cause an operation failure or give damage to the module.

## [Wiring Precautions]

### CAUTION

- Completely turn off the externally supplied power used in the system when placing wiring. Not completely turning off all power could result in electric shock or damage to the product.
- When turning on the power supply or operating the module after installation or wiring work, be sure that the module's terminal covers are correctly attached. Not attaching the terminal cover could result in electric shock.
- External connections shall be crimped or pressure welded with the specified tools, or correctly soldered.  
Imperfect connections could result in short circuit, fires, or erroneous operation.

## [Wiring Precautions]



### CAUTION

- Fully connect the connector to the module.
- When wiring in the programmable controller, be sure that it is done correctly by checking the product's rated voltage and the terminal layout. Connecting a power supply that is different from the rating or incorrectly wiring the product could result in fire or damage.
- Make sure to place the communication and power cables to be connected to the module in a duct or fasten them using a clamp. If the cables are not placed in a duct or fastened with a clamp, their positions may be unstable or moved, and they may be pulled inadvertently. This may damage the module and the cables or cause the module to malfunction due to poor cable connection.
- Wire the module correctly after confirming the type of the connected interface. If the cable is connected to a different interface or wired incorrectly, it may cause a fire or breakdown.
- Tighten the terminal screws with the specified torque. If the terminal screws are loose, it could result in short circuits, fire, or erroneous operation. Tightening the terminal screws too far may cause damages to the screws and/or the module, resulting in fallout, short circuits, or malfunction.
- When removing a communication or power cable from the module, do not pull the cable part. For the cable with connector, hold the connector part connected to the module. When removing the cable connected to the terminal block, first loosen the screws on the terminal block. Pulling a cable connected to the module may damage the module and/or cable and cause a malfunction due to poor contact.
- Be sure there are no foreign substances such as sawdust or wiring debris inside the module. Such debris could cause fires, damage, or erroneous operation.
- The module has an ingress prevention label on its top to prevent foreign matter, such as wire offcuts, from entering the module during wiring. Do not peel this label during wiring. Before starting system operation, be sure to peel this label because of heat dissipation.

## [Startup/Maintenance Precautions]

### **DANGER**

- Do not touch the terminals while power is on.  
Doing so could cause shock or erroneous operation.
- Switch off all phases of the externally supplied power used in the system when cleaning the module or retightening the terminal or module mounting screws. Not doing so could result in electric shock. Undertightening of terminal screws can cause a short circuit or malfunction. Overtightening of screws can cause damages to the screws and/or the module, resulting in fallout, short circuits, or malfunction.

### **CAUTION**

- The online operations conducted for the CPU module being operated, connecting the peripheral device (especially, when changing data or operation status), shall be conducted after the manual has been carefully read and a sufficient check of safety has been conducted. Operation mistakes could cause damage or problems with of the module.
- Do not disassemble or modify each modules.  
Doing so could cause failure, malfunction, injury or fire.
- Use any radio communication device such as a cellular phone or a PHS phone more than 25cm (9.85 inch) away in all directions of the programmable controller. Not doing so can cause a malfunction.
- Completely turn off the externally supplied power used in the system before mounting or removing the module. Not doing so could result in damage to the product.
- Do not mount/remove the module to/from the base unit or terminal block more than 50 times (IEC 61131-2 compliant), after the first use of the product.  
Failure to do so may cause module malfunctions.
- Before touching the module, always touch grounded metal, etc. to discharge static electricity from human body, etc. Not doing so can cause the module to fail or malfunction.

## [Operating Precautions]



### **CAUTION**

- Please read the manual carefully and ensure the safety before performing control operations (especially, data or program modification and operation status change) to a running programmable controller. Incorrect data or program modifications or improper operating status change may cause system malfunctions, mechanical damages or accidents.

## [Disposal Precautions]



### **CAUTION**

- When disposing of this product, treat it as industrial waste.

## Revisions

\* The manual number is noted at the lower right of the cover.

Print Date	*Manual Number	Revision
Sep., 2005	IB(NA)-0800329-A	First Edition
Oct., 2006	IB(NA)-0800329-B	<u>Partial correction</u> SAFETY PRECAUTIONS, CHAPTER 6, CHAPTER 7.
Feb., 2008	IB(NA)-0800329-C	<u>Change of a term</u> "PLC" was changed to "programmable controller". <u>Partial correction</u> SAFETY PRECAUTIONS, Chapter 2, Section 3.1, Chapter 4, Section 5.1, 5.2, Chapter 6, 7
Aug., 2008	IB(NA)-0800329-D	<u>Partial correction</u> SAFETY PRECAUTIONS, About Manual, Compliance with the EMC and Low Voltage Directives, Section 3.1

This manual confers no industrial property rights or any rights of any other kind, nor does it confer any patent licenses. Mitsubishi Electric Corporation cannot be held responsible for any problems involving industrial property rights which may occur as a result of using the contents noted in this manual.



---

---

# CONTENTS

---

---

1. Overview .....	1
2. Performance Specifications .....	2
3. Mounting and Installation .....	4
3.1 Handling Precautions .....	4
3.2 Installation Environment .....	4
4. Part Names .....	5
5. External Wiring .....	7
5.1 Connecting the RS-232 line .....	7
5.2 Connecting the RS-422/485 line .....	9
6. Setting from GX Developer .....	16
7. External Dimensions .....	19

## **About Manual**

The following manual is also related to this product.  
In necessary, order it by quoting the details in the table below.

### Related Manual

Manual name	Manual No. (Model code)
MODBUS <sup>®</sup> Interface Module User's Manual	SH-080578ENG (13JR86)

Before using this module, be sure to read the MODBUS<sup>®</sup> Interface Module User's Manual.

## **Compliance with the EMC and Low Voltage Directives**

- (1) For programmable controller system  
To configure a system meeting the requirements of the EMC and Low Voltage Directives when incorporating the Mitsubishi programmable controller (EMC and LowVoltage Directives compliant) into other machinery or equipment, refer to Chapter 9 "EMC AND LOW VOLTAGE DIRECTIVES" of the QCPU User's Manual (Hardware Design, Maintenance and Inspection).  
The CE mark, indicating compliance with the EMC and Low Voltage Directives, is printed on the rating plate of the programmable controller.
- (2) For the product  
No additional measures are necessary for the compliance of this product with the EMC and Low Voltage Directives.

# 1. Overview

This manual explains how to install the QJ71MB91 MODBUS<sup>®</sup> interface module (hereinafter referred to as QJ71MB91) and how to wire it to other devices.

MODBUS<sup>®</sup> is a registered trademark of Schneider Electric SA.

Table 1.1 Packing list

Model	Product name	Quantity
QJ71MB91	QJ71MB91 MODBUS <sup>®</sup> interface module	1
	Terminating resistor 330 $\Omega$ 1/4 W (for RS-422 communication) *1	2
	Terminating resistor 110 $\Omega$ 1/2 W (for RS-485 communication) *1	2

\*1 The terminating resistor type can be distinguished as shown below.

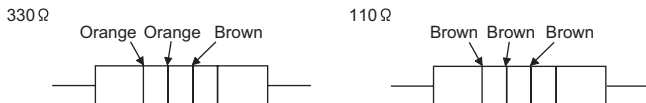

Figure 1.1 How to distinguish terminating resistors

## 2. Performance Specifications

The following describes the performance specifications of the QJ71MB91. For the general specifications of the QJ71MB91, refer to the user's manual of the CPU module used.

Table 2.1 Performance specifications

Item		Specifications												
Transmission specifications	Number of interfaces	RS-232×1 channel RS-422/485×1 channel												
	Transmission speed	<table border="1"> <tr> <td>300</td> <td>600</td> <td>1200</td> <td>2400</td> </tr> <tr> <td>4800</td> <td>9600</td> <td>14400</td> <td>19200</td> </tr> <tr> <td>28800</td> <td>38400</td> <td>57600</td> <td>115200</td> </tr> </table> (bps) Communication is available with total transmission speed of two interfaces within 115200bps.	300	600	1200	2400	4800	9600	14400	19200	28800	38400	57600	115200
	300	600	1200	2400										
	4800	9600	14400	19200										
28800	38400	57600	115200											
Transmission distance (Overall distance)	RS-232	Max. 15m (49.2 ft.)												
	RS-422/485	Max. 1200m (4592.4 ft.) (Overall distance)												
Master function	Automatic communication function	Number of slaves *1	32 per channel											
		Function (for send)	7 functions											
		Input area size	4k words											
		Output area size	4k words											
	Dedicated instruction	Number of instructions that can be executed concurrently *2	1 per channel											
		Function (for send)	MBRW instruction: 9 functions MBREQ instruction: 19 functions											
		Input area size	Max. 253 bytes per instruction											
		Output area size	Max. 253 bytes per instruction											

(Continued to next page)

Table 2.1 Performance specifications (Continued)

Item		Specifications	
Slave function	Automatic response function	Function (for receive)	17 functions
	MODBUS® Device size	Coil	64k points
		Input	64k points
		Input register	64k points
		Holding register	64k points
		Extended file register	Max. 4086k points
	No. of simultaneously acceptable request messages		1 request per channel
Station No.		1 to 247	
Number of occupied I/O points		32 points	
5VDC internal current consumption		0.31A	
External dimensions		98 (3.86 in.) (H)×27.4 (1.08 in) (W)×90 (3.54 in) (D) [mm]	
Weight		0.20kg	

\*1 Indicates the maximum number of slaves that can be communication targets.

\*2 Indicates the maximum number of dedicated instructions that can be executed simultaneously from a sequence program.

---

---

## 3. Mounting and Installation

---

---

### 3.1 Handling Precautions

- (1) Since the case of the QJ71MB91 is made of resin, do not drop or give it hard impact.
- (2) Before handling the modules, touch a grounded metal object to discharge the static electricity from the human body.  
Failure to do so may cause failure or malfunctions of the module.
- (3) Tighten the screws, such as module fixing screws within the following ranges.

Table 3.1 Tightening torque

Screw	Tightening torque range	Remarks
Terminal screw for RS-422/485 terminal block (M3 screw)	0.42 to 0.58N·m	—
Mounting screw for RS-422/485 terminal block (M3.5 screw)	0.66 to 0.89N·m	—
RS-232 cable connector screw (M2.6 screw)	0.20 to 0.39N·m	Screw hole depth:L=3.2mm or less (Internal length from the surface)
Module fixing screw (normally not required) (M3 screw) *1	0.36 to 0.48N·m	—

\*1 The module can be easily fixed onto the base unit using the hook at the top of the module. However, it is recommended to secure the module with the module fixing screw if the module is subject to significant vibration.

### 3.2 Installation Environment

Refer to the user's manual of the CPU module used.

## 4. Part Names

This section provides the names of the QJ71MB91 parts.

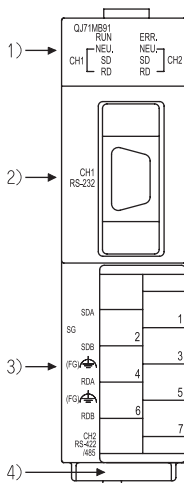



Figure 4.1 QJ71MB91 external diagram

Table 4.1 Part names and descriptions

Name		Description
1)	Indicator LED	Indicator LEDs (  This chapter (1))
2)	CH1 side RS-232 interface	RS-232 interface for serial communication with target devices (D-Sub 9 pin)
3)	CH2 side RS-422/485 interface	RS-422/485 interface for serial communication with target devices (Detachable terminal block)
4)	Serial number plate	Indicates the serial No. of the QJ71MB91.

(1) Display LED list

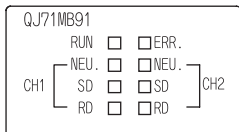

Figure 4.2 QJ71MB91 LEDs

Table 4.2 Description of LEDs

LED name		Indication		Description	
				On/Flashing	OFF
RUN		Normal operation		Normal	Watch dog timer error, hardware fault
ERR.		Error indication		Error occurred	Normal
CH1 /CH2	NEU.	Neutral status	Master function	Request message not transmitted	Waiting for response message from slave
			Slave function	Waiting for request message from master	Request message being processed
	SD	Transmission status	Data being transmitted	Data not transmitted	
	RD	Reception status	Data being received	Data not received	



## 5. External Wiring

### 5.1 Connecting the RS-232 line

This section explains the standard method for connecting the RS-232 line.

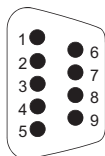

Pin No.	Signal code	Signal name	Signal direction QJ71 MB91 ↔ Target device
1	(Use prohibited)	(Use prohibited)	—
2	RD(RXD)	Reception data	←
3	SD(TXD)	Transmission data	→
4	(Use prohibited)	(Use prohibited)	—
5	SG(GND)	Signal ground	↔
6	(Use prohibited)	(Use prohibited)	—
7 <sup>*1</sup>	—	Output for cable disconnection detection	↔
8 <sup>*1</sup>	—	Input for cable disconnection detection	←
9	(Use prohibited)	(Use prohibited)	—

Figure 5.1 Pin No. and signals for RS-232 connection

\*1 Connect Pin 8 to Pin 7.

Without connecting Pin 7 and 8, Pin 8 turns off and the CS signal may turn off (Error code: 7403H).

#### (1) Connection precautions

##### (a) Connection cable's FG signal line and shield

Connect the connection cable's FG signal line and shield as follows:

Table 5.1 Connection cable's FG signal line and shield

Item	Connection on the QJ71MB91 side	Remarks
Connection cable's FG signal	Connect to the QJ71MB91 side connector housing.	Do not short-circuit the FG and SG signal lines of the connection cable.
Connecting cable's shield	Connect to the target device's FG terminal or the QJ71MB91 side connector housing.	When the FG and SG signal lines are connected inside the target device, do not connect the FG signal line to the QJ71MB91 side.

(b) Connection diagram

Connect the lines as shown below.

Connect the FG terminal on the target device and the QJ71MB91 side using the shield of the connection cable.

Connect each signal line other than SG with the SG signal line in twisted pair.

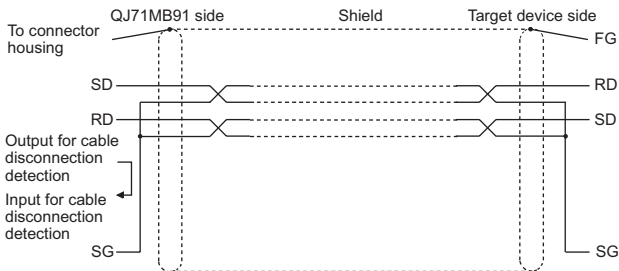

Figure 5.2 RS-232 cable shield

(2) Interface connector

For the QJ71MB91 RS-232 interface connector, use a 9-pin D sub (female) screw type connector.

Use metric screws.

### (3) Connection example

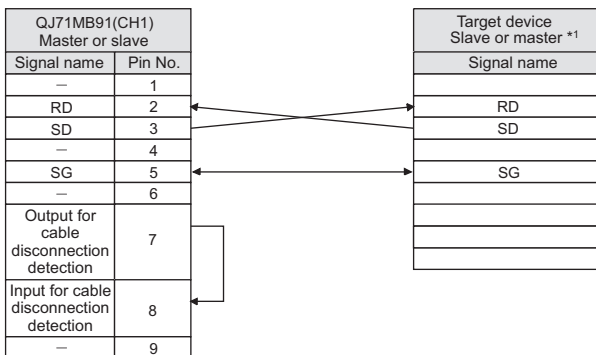

Figure 5.3 RS-232 connection example

\*1 For other signal wirings on the target device, refer to the instruction manual of the target device.

## 5.2 Connecting the RS-422/485 line

This section explains the standard method for connecting the RS-422/485 line.

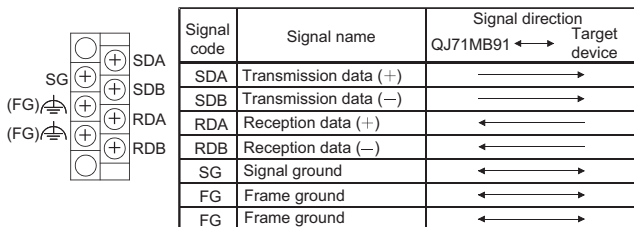

Figure 5.4 RS-422/485 terminal block specifications

## (1) Connection precautions

### (a) When connecting SG and FG signal lines

When connecting the QJ71MB91 side SG and FG signal lines to the target device, connect them according to the specifications of the target device.

### (b) Connecting cable's shield

Connect the shield of the connection cable to either FG terminal on the connected device.

If normal data communication is not available due to external noise even with the above-mentioned wiring, perform the following wiring.

Table 5.2 When external noise disturbs normal communications

Preventive measures
Make connection between the FGs of both stations with the shield of the connection cable. For the target device side, follow the instruction manual of the target device.
Connect the (FG) of the QJ71MB91 to the FG terminal of the power supply module on the station to which the QJ71MB91 is installed, or to the FG terminal of the control panel on which the QJ71MB91 programmable controller is installed.
Connect nA and nB of each signal line of the connection cable in a pair.

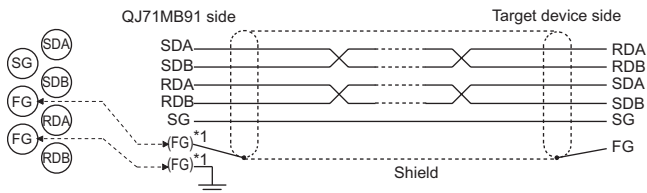

Correspondence between RS-422/485 terminal block and signal position.

\*1 The QJ71MB91's FG terminal can be connected to either one.

Figure 5.5 RS-422/485 cable shield

(c) Terminating resistor

Terminating resistor setting (or connection) is required for the stations of both ends.

For the QJ71MB91 side, connect a terminating resistor (packed with the QJ71MB91), referring to this section and according to the specifications of the target device.

For the target device side, connect or set a terminating resistor according to the instruction manual of the target device.

(Terminating resistor to be connected to the QJ71MB91)

For RS-422 communications, connect a "330  $\Omega$  1/4 W" terminating resistor.

For RS-485 communications, connect a "110  $\Omega$  1/2 W" terminating resistor.

(How to distinguish terminating resistors)

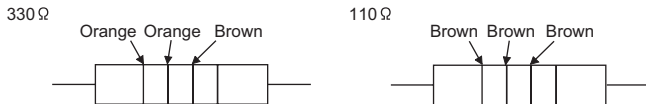

Figure 5.6 How to distinguish terminating resistors

(d) When data communications are not possible at all

If data cannot be exchanged with the target device at all, check the polarity of the target device. If the polarities of the QJ71MB91 and the target device do not match, reverse the polarity of each signal on either device side. This may enable the data communications.

(e) Devices connected to RS-422/485 interface

Devices connected to the QJ71MB91 RS-422/485 interface must be all RS-422 or all RS-485.

- (f) Preventive measures against faulty data reception on the target device side

If the target device receives error data, install a pull-up or pull-down resistor to the target device as shown below.

Installing a pull-up or pull-down resistor (resistance value: approx.  $4.7\text{ k}\Omega$ ,  $1/4\text{ W}$ ) can prevent the reception of error data.

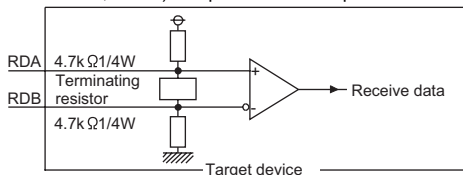

Figure 5.7 Preventive measures against faulty data reception

Error data will not be received if a pull-up or pull-down resistor is connected on the target device side.

- (2) RS-422/485 cable specification

The RS-422/485 cable should meet the following specifications and used within 1200m(3937 ft).

When connecting to multiple devices (1:n), ensure that the overall distance is within 1200 m (3937 ft.).

Table 5.3 RS-422/485 cable specifications

Item	Description
Cable type	Shielded cable
Number of pairs	3P
Conductor resistance (20 °C )	88.0 $\Omega$ /km or less
Insulation resistance	10000 M $\Omega$ - km or more
Dielectric withstand voltage	500V DC, 1 minute
Electrostatic capacitance (1 kHz)	60nF/km or less on average
Characteristic impedance (100 kHz)	$110 \pm 10\ \Omega$
Recommended conductor size	0.2 mm <sup>2</sup> to 0.75 mm <sup>2</sup>

### (3) Connection examples

#### (a) Connection for 1:1 communication

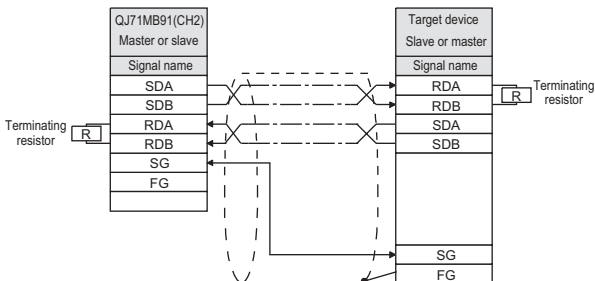

Figure 5.8 Connection for 1:1 communication

#### (b) Connection for 1:n communication when host is master

##### • For 4-wire communications

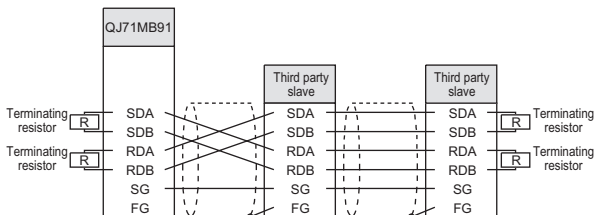

Figure 5.9 Connection (for 1:n communication, 4 wire) when host is master

##### • For 2-wire communications

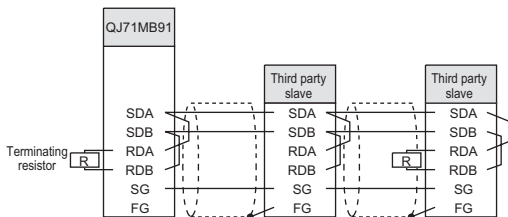

Figure 5.10 Connection (for 1:n communication, 2 wires) when host is master

(c) Connection for 1:n communications when host station is slave and communicating with a third party master station (RS-422/485 interface)

• For 4-wire communications

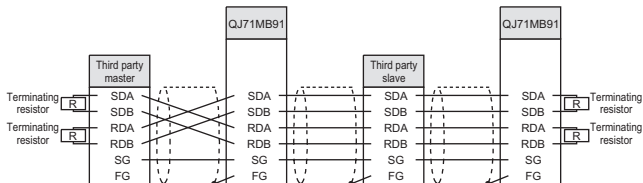

Figure 5.11 Connection (for 1:n communication, 4 wires) when host is slave

• For 2-wire communications

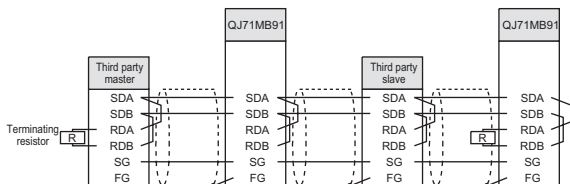

Figure 5.12 Connection (for 1:n communication, 2 wires) when host is slave

(d) Connection for 1:n communications when host station is slave and communicating with a third party master station (RS-232 interface) (Link operation setting)

• For 4-wire communications

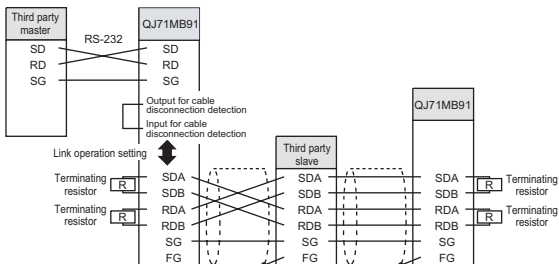

Figure 5.13 Connection (for link operation setting, 1:n communication, 4 wires) when host is slave



• For 2-wire communications

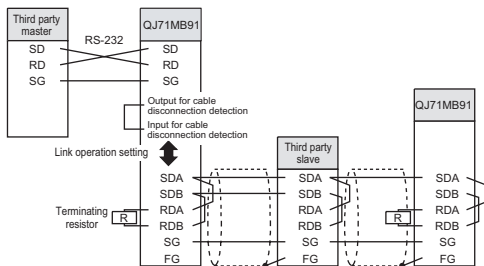

Figure 5.14 Connection (for link operation setting, 1:n communication, 2 wires) when host is slave

## 6. Setting from GX Developer

In order to use the QJ71MB91, make the intelligent function module switch setting from GX Developer.

Table 6.1 Intelligent function module switch

Switch No.	Description		Default	Reference
Switch 1	CH1	Mode setting	0000H	(1) in this section
Switch 2		Communication speed/ transmission setting	0700H	(2) in this section
Switch 3	CH2	Mode setting	0000H	(1) in this section
Switch 4		Communication speed/ transmission setting	0700H	(2) in this section
Switch 5	CH1,2 station No. setting		0000H	(3) in this section

(1) Mode setting (Switch 1: CH1 side, Switch 3: CH2 side)

Set the operation mode of the QJ71MB91.

Table 6.2 Mode setting

Set value *1		Operation mode		Description
Switch 1	Switch 3	CH1	CH2	
0000H	0000H	Master function	Master function	Master function : Performs communication as master station.
0000H	0001H	Master function	Slave function	
0001H	0000H	Slave function	Master function	Slave function : Performs communication as slave station.
0001H	0001H	Slave function	Slave function	
0002H	0002H	Link operation (Slave function) *2		Relays data between CH1 and CH2 with the link operation function.
000DH	000DH	Hardware test		Performs test to check the RAM and ROM of QJ71MB91.
000EH	000DH	Self-loopback test	—	Performs tests to check the send/receive function of the QJ71MB91 and communications with the programmable controller CPU.
000DH	000EH	—	Self-loopback test	
000EH	000EH	Self-loopback test	Self-loopback test	

\*1 Setting a value other than indicated in the table results in a switch error.

\*2 For the link operation (slave function), set "0002H" to both Switch 1 and 3. Setting it to only one switch results in a switch error.

- (2) Communication speed/transmission setting (Switch 2: CH1 side, Switch 4: CH2 side)

Set the transmission speed and other specifications for communications with the target device.

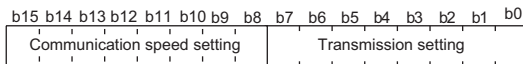

Figure 6.1 Structure of communication speed and transmission settings

(a) Transmission setting

Table 6.3 Transmission setting

Bit	Item		OFF (0)	ON (1)	Description
b0	MODBUS <sup>®</sup> device assignment parameter starting method	Switch 2	Start with the default parameters	Start with the user-set parameters *1	The MODBUS <sup>®</sup> device assignment parameter starting method must be set only for Switch 2 regardless of the channel used. When "Start with the default parameters" is set, the module is started with the parameters assigned by default. When "Start with the user-set parameters" is set, the module is started with the MODBUS <sup>®</sup> device assignment parameters set on the sequence program or GX Configurator-MB. When setting parameters using the GX Configurator-MB, turn the MODBUS <sup>®</sup> device assignment parameter start method ON.
		Switch 4	Fixed to OFF(0)		—
b1	Data bit *2		8	7	Set data bits.
b2	Parity bit presence		Present	Not present	Specify whether parity bit is present or not. In the case of "Present", vertical parity check is performed.
b3	Even/ odd parity		Even	Odd	Set even or odd parity. This setting is valid only when "Parity bit presence" is set to "Present".
b4	Stop bit		1	2	Set the stop bit.
b5	Frame mode		RTU mode	ASCII mode	Set the frame mode.
b6	Online change		Disable	Enable	Set whether to enable or disable data writing to the RUN-status programmable controller CPU by a request message from the master. If this is set to "Disable", when a message requesting the device write is received from the master, the QJ71MB91 returns an error response. This setting is valid only when the slave function is set for the channel.
b7	Not used		Fixed to OFF(0)		—

\*1 Set the MODBUS<sup>®</sup> device assignment parameters before sending request messages to the QJ71MB91.

If a request message is sent before the setting, the QJ71MB91 will send a response message (error completion). (The slave function does not operate.)

\*2 Set it to OFF (8 bits) in RTU mode.

(b) Communication speed setting \*1\*2

Table 6.4 Communication speed setting

Communication speed	Bit position	Communication speed	Bit position
	b15 to b8		b15 to b8
300bps	00H	14400bps	06H
600bps	01H	19200bps	07H
1200bps	02H	28800bps	08H
2400bps	03H	38400bps	09H
4800bps	04H	57600bps	0AH
9600bps	05H	115200bps	0BH

\*1 Total communication speed for 2 channels can be set within 115200bps.

\*2 Do not set any value or set 07H (Initial value) in the communication speed setting for an unused channel.

(3) CH1, 2 station No. setting (Switch 5)

Set slave station No. of the QJ71MB91.

For the master function, set 00H.

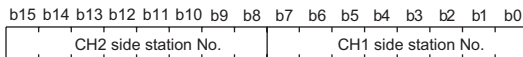

Figure 6.2 CH1,2 station No. setting structure

Table 6.5 Station No. setting

Set value *1	Description
1H to F7H	Set a slave station No. (1 to 247).

\*1 Setting a value outside the range shown in the table results in a switch error.

## 7. External Dimensions

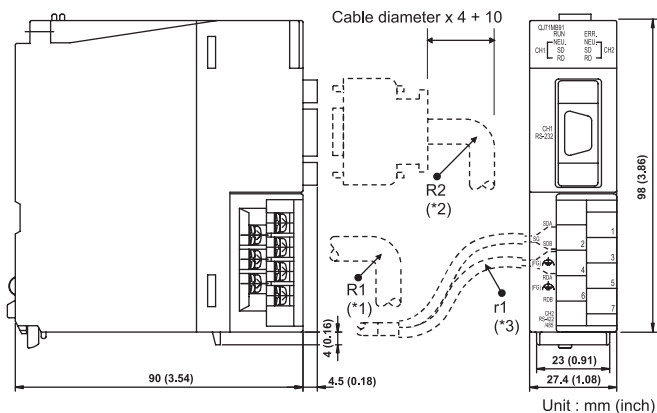

Figure 7.1 External dimensions

- \*1 R1(Bending radius near terminal block):Outer cable diameter  $\times$  4
- \*2 R2(Bending radius near connector) :Outer cable diameter  $\times$  4
- \*3 r1(Bending radius near crimp contact) :Connectable as long as not bended extremely

MODBUS is a registered trademark of Schneider Electric SA.  
 All other company names and product names used in this manual are trademarks or registered trademarks of their respective companies.

## Warranty

Mitsubishi will not be held liable for damage caused by factors found not to be the cause of Mitsubishi; machine damage or lost profits caused by faults in the Mitsubishi products; damage, secondary damage, accident compensation caused by special factors unpredictable by Mitsubishi; damages to products other than Mitsubishi products; and to other duties.

### For safe use

- This product has been manufactured as a general-purpose part for general industries, and has not been designed or manufactured to be incorporated in a device or system used in purposes related to human life.
- Before using the product for special purposes such as nuclear power, electric power, aerospace, medicine or passenger movement vehicles, consult with Mitsubishi.
- This product has been manufactured under strict quality control. However, when installing the product where major accidents or losses could occur if the product fails, install appropriate backup or failsafe functions in the system.

Country/Region	Sales office/Tel	Country/Region	Sales office/Tel
U.S.A	Mitsubishi Electric Automation Inc. 500 Corporate Woods Parkway Vernon Hills, IL 60061, U.S.A. Tel : +1-847-478-2100	Hong Kong	Mitsubishi Electric Automation (Hong Kong) Ltd. 10th Floor, Manulife Tower, 169 Electric Road, North Point, Hong Kong Tel : +852-2887-8870
Brazil	MELCO-TEC Rep. Com.e Assessoria Tecnica Ltda. Rua Correia Dias, 184, Edificio Paraiso Trade Center-8 andar Paraiso, Sao Paulo, SP Brazil Tel : +55-11-5908-8331	China	Mitsubishi Electric Automation (Shanghai) Ltd. 4/F Zhi Fu Plaza, No.80 Xin Chang Road, Shanghai 200003, China Tel : +86-21-6120-0808
Germany	Mitsubishi Electric Europe B.V. German Branch Gothaer Strasse 8 D-40880 Ratingen, GERMANY Tel : +49-2102-486-0	Taiwan	Setsumo Enterprise Co., Ltd. 6F No.105 Wu-Kung 3rd.Rd, Wu-Ku Hsiang, Taipei Hsine, Taiwan Tel : +886-2-2299-2499
U.K	Mitsubishi Electric Europe B.V. UK Branch Travellers Lane, Hatfield, Hertfordshire., AL10 8XB, U.K. Tel : +44-1707-276100	Korea	Mitsubishi Electric Automation Korea Co., Ltd. 1480-6, Gayang-dong, Gangseo-ku Seoul 157-200, Korea Tel : +82-2-3660-9552
Italy	Mitsubishi Electric Europe B.V. Italian Branch Centro Dir. Colleoni, Pal. Perseo-Ingr.2 Via Paracelso 12, I-20041 Agrate Brianza., Milano, Italy Tel : +39-039-60531	Singapore	Mitsubishi Electric Asia Pte, Ltd. 307 Alexandra Road #05-01/02, Mitsubishi Electric Building, Singapore 159943 Tel : +65-6470-2460
Spain	Mitsubishi Electric Europe B.V. Spanish Branch Carretera de Rubi 76-80, E-08190 Sant Cugat del Valles, Barcelona, Spain Tel : +34-93-565-3131	Thailand	Mitsubishi Electric Automation (Thailand) Co., Ltd. Bang-Chan Industrial Estate No.111 Moo 4, Serithai Rd, T.Kannayao, A.Kannayao, Bangkok 10230 Thailand Tel : +66-2-517-1326
France	Mitsubishi Electric Europe B.V. French Branch 25, Boulevard des Bouvets, F-92741 Nanterre Cedex, France TEL: +33-1-5568-5568	Indonesia	P.T. Autoteknindo Sumber Makmur Muara Karang Selatan, Block A/Utara No.1 Kav. No.11 Kawasan Industri Pergudangan Jakarta - Utara 14440, P.O.Box 5045 Jakarta, 11050 Indonesia Tel : +62-21-6630833
South Africa	Circuit Breaker Industries Ltd. Private Bag 2016, ZA-1600 Isando, South Africa Tel : +27-11-928-2000	India	Messung Systems Pvt. Ltd. Electronic Sadan NO:III Unit No15, M.I.D.C Bhosari, Pune-411026, India Tel : +91-20-2712-3130
		Australia	Mitsubishi Electric Australia Pty. Ltd. 348 Victoria Road, Rydalmere, N.S.W 2116, Australia Tel : +61-2-9684-7777

## MITSUBISHI ELECTRIC CORPORATION

HEAD OFFICE : TOKYO BUILDING, 2-7-3 MARUNOUCHI, CHIYODA-KU, TOKYO 100-8310, JAPAN  
NAGOYA WORKS : 1-14, YADA-MINAMI 5-CHOME, HIGASHI-KU, NAGOYA, JAPAN

When exported from Japan, this manual does not require application to the Ministry of Economy, Trade and Industry for service transaction permission.

Specifications subject to change without notice.  
Printed in Japan on recycled paper.